



Centralia City Light
New Residential Overhead Service Reference

New Electric Service Hookup to Existing Power Facilities
Permanent Single-Family Residential Services
360-330-7512

This handout is a quick reference of the basic information needed to install a new Overhead Electric 120/240V service to a single-family residential structure. In some situations, a 7200V primary line extension may also be required.

Customer Responsibilities:

1. Determine the service size amp rating you want (200, 320, or 400 amp).
2. Submit a completed Application for Service.
3. Determine an approved meter location and install your electrical meter base and panel.
4. Obtain an electrical work permit from the Washington State Department of Labor & Industries (360-902-5242).
5. Call the Utilities Underground Location Center (UULC) two full working days before you dig: Dial **811**.
6. Notify other utilities of your project.
7. Provide a clear path for your overhead electric service wire.
8. Sign a Utility Easement Agreement if required.
9. Obtain an approved electrical inspection by State L&I Department (360-902-5242).
10. Set up an account and pay all required fees at the Customer Service Center (500 N. Pearl Street, Centralia, WA).
11. After the electrical inspection has been completed and approved, contact Centralia City Light and request that your service be energized.

Centralia City Light Responsibilities:

- Determine connection fees and if a Utility Easement Agreement is required. Charges vary due to the type of service you request and the type of system we have in your area. Contact your CCL Engineering Department for connection fee information.
- Install your overhead service line conductors.
- Install your meter and energize your system.

Scheduling: If engineering is not required, services are typically installed and energized 3 to 5 working days after you have passed your inspection.

Prior To The City Energizing The Service, Your Electrical Panel Must Be Approved By The Washington State Department Of Labor & Industries (360-902-5242).

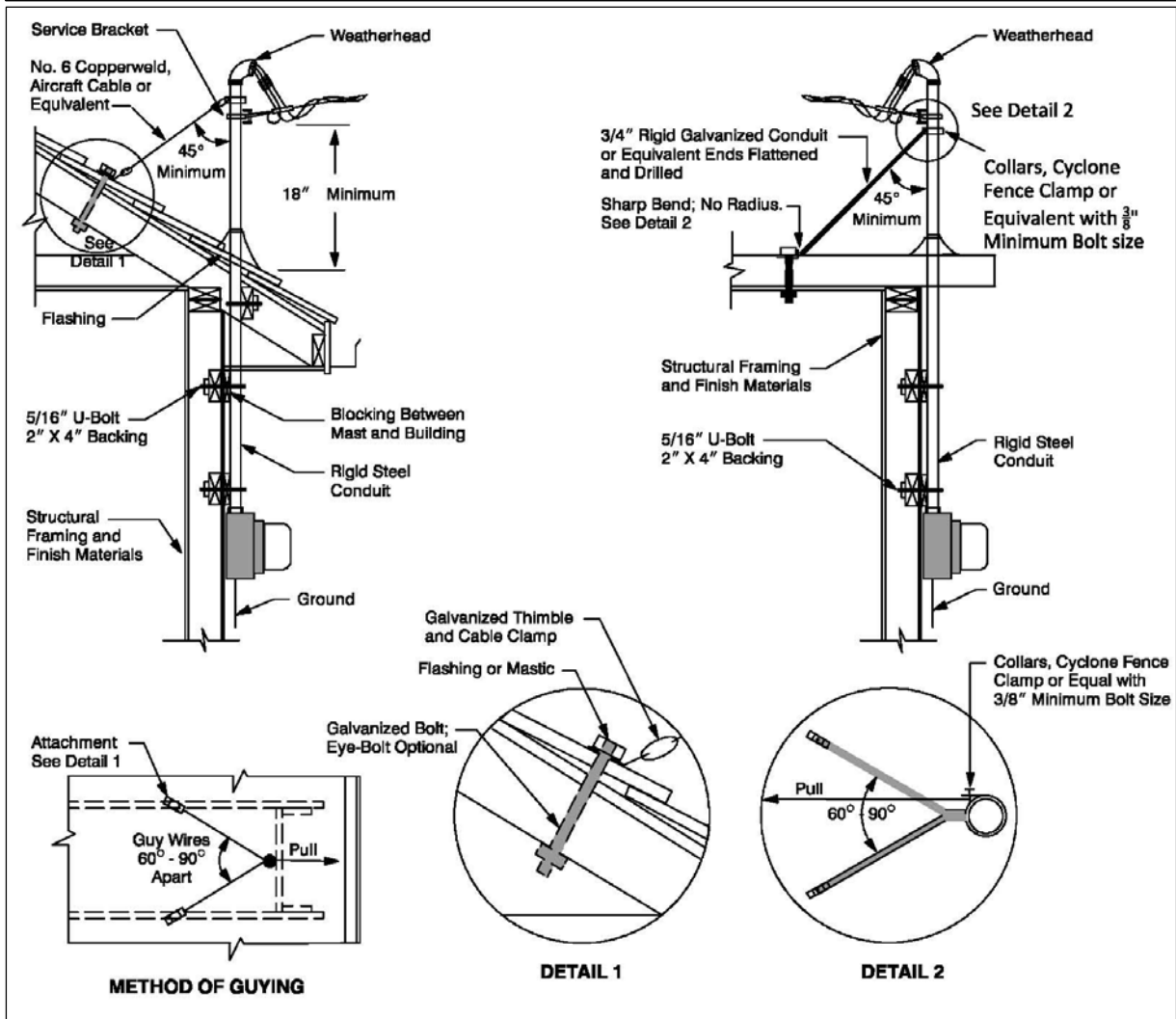
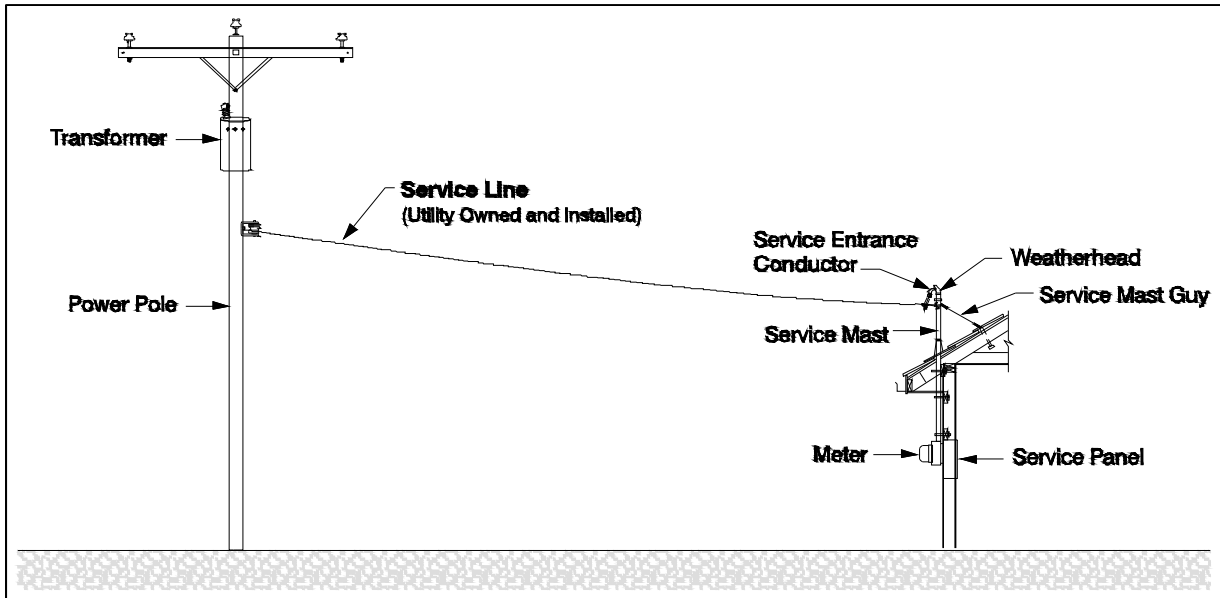

Typical Installations